

Mechanical Shutter Assembly

Description

SHT934 is a mechanical shutter assembly designed for digital still cameras or other devices using CCD or CMOS imagers.

Key Features

- Normal open or close selectable
- Front protective window
- Easy integration with many off-the-shelf SUNEX DSL series lenses
- Optional IRC30 reflective IR Cut filter replaces opaque shutter (PN SHT934-IRC30)
- Recommended operating voltage: 3.3v
- Speed: **See timing figure on page 3**
- Weight: 4.1g
- Shutter aperture: 4.5mm
- Electricity: 167mA-168mA
- Frequency: Max 133HZ
 - § Normal 69HZ
- T1(Close): Voltage 2.6V 1.2ms-1.8ms
 - Voltage 3.0V 0.9ms-1.2ms
- T2(Open): Voltage 2.6V 1.6ms-2.8ms

SHT934



Dimension (shown with optional DSL914 lens):

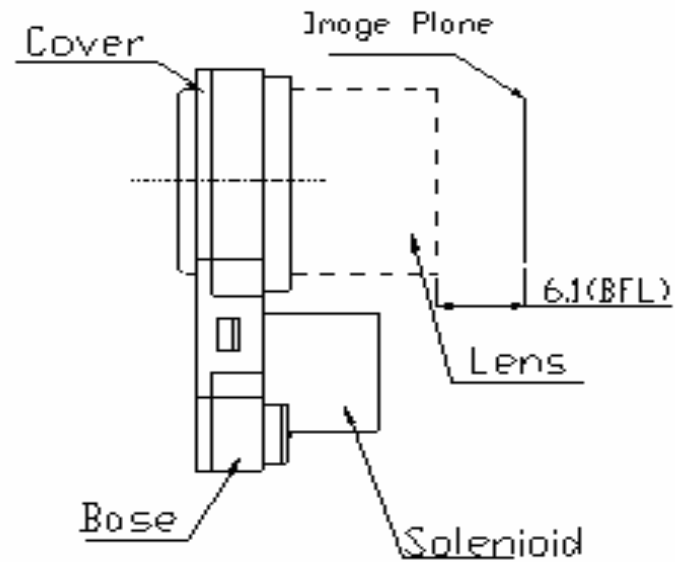
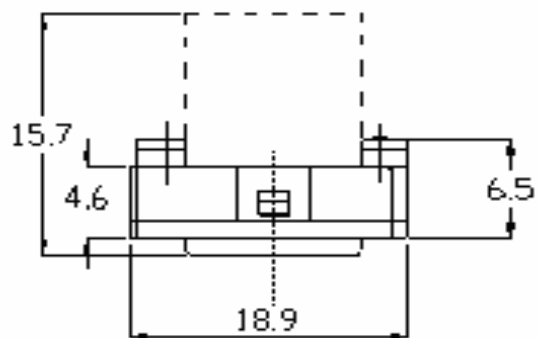
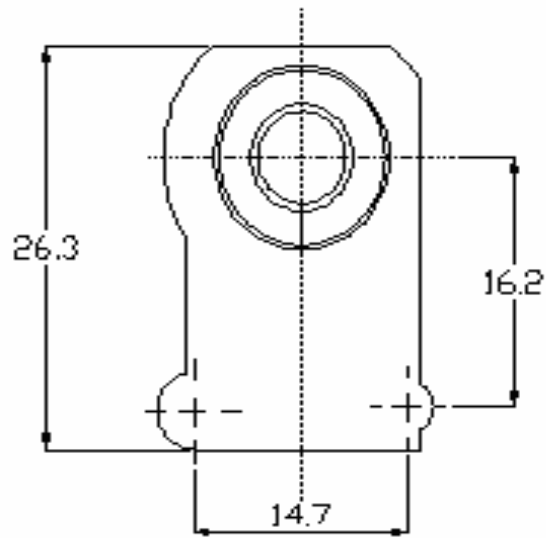

SUBJECT TO CHANGE WITHOUT NOTICE

Sunex Inc.

Telephone: +001 760.602.0988

Order samples online at www.optics-online.com

